

INSTALLATION DRAWINGS

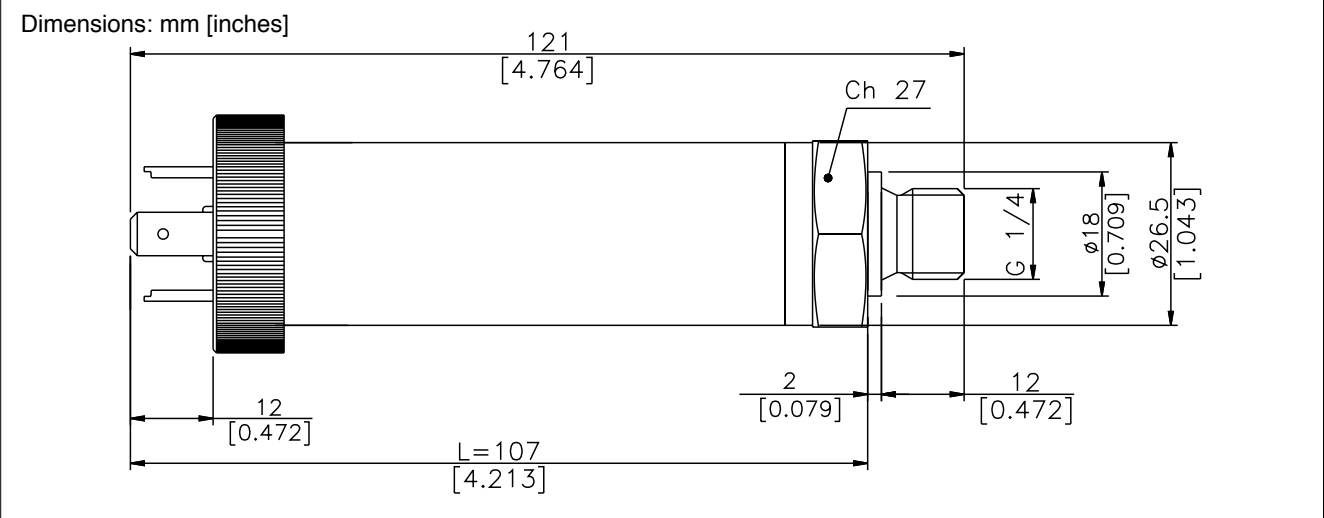

PRESSURE CONNECTION

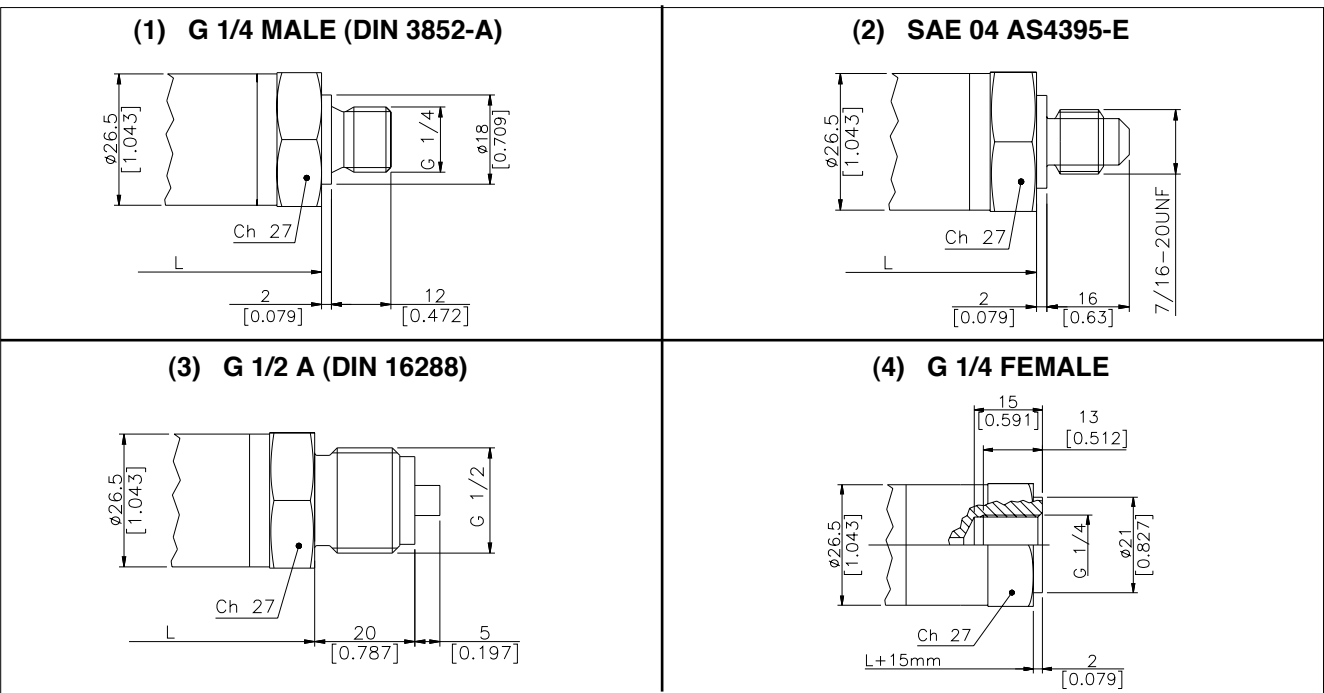

ELECTRICAL CONNECTION

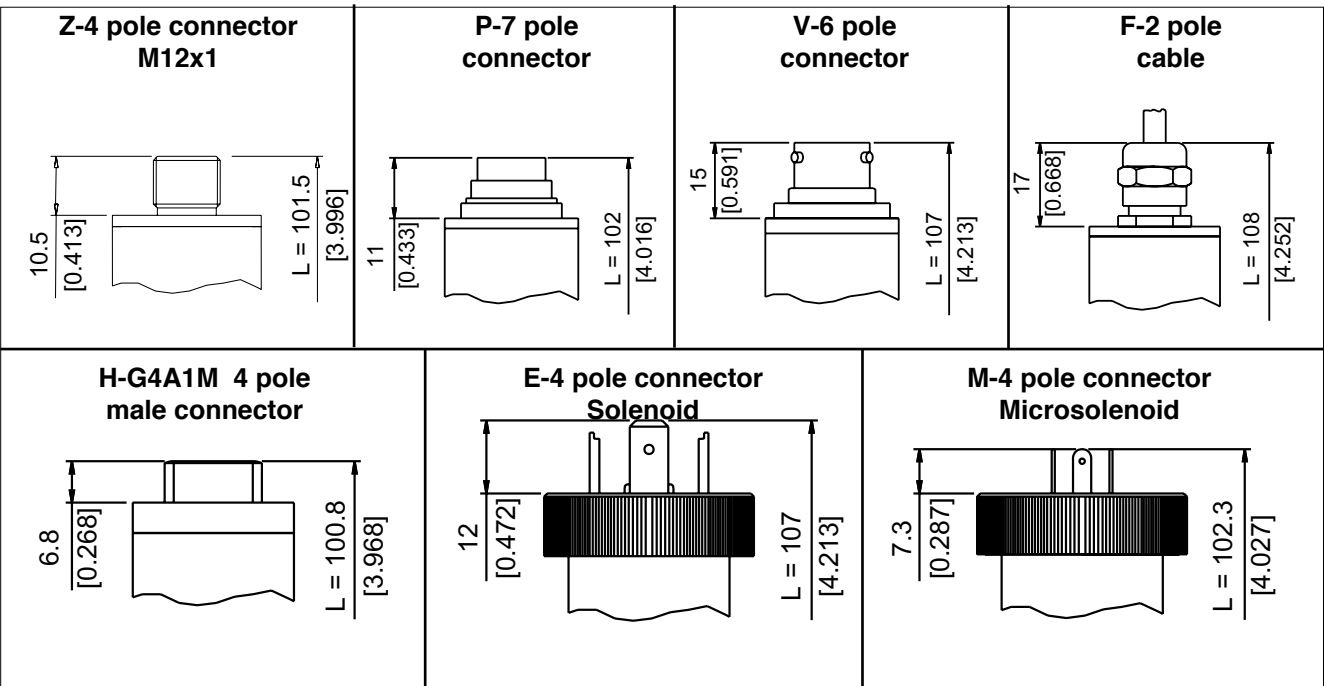

INTRINSIC SAFETY CHARACTERISTICS

		II 1G Ex ia IIC T6	II 1G Ex ia IIC T5	II 1G Ex ia IIC T4
Maximum voltage	Ui	30Vdc	30Vdc	30Vdc
Maximum current	Ii	100mA	100mA	100mA
Maximum power	Pi	0.75W	0.75W	0.75W
Maximum inductance (*)	Li	0.25 mH	0.25 mH	0.25 mH
Maximum capacity (*)	Ci	26nF	26nF	26nF
Temperature of the fluid		-40...+60°C	-40...+70°C	-40...+80°C
Ambient temperature		-40...+60°C	-40...+70°C	-40...+80°C

(*) includes inductance levels and capacity of a cable: (typical L 1µH/m and typical C 100 pF/m) with maximum length 15mt.

ELECTRICAL CONNECTION - Connectors

P - 7-pole connector

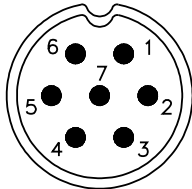

Male connector 09-127-09-07
Protection IP67

V - 6-pole connector

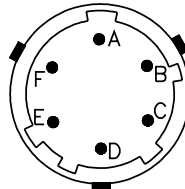

Male connector VPT02A10-6PT2
Protection IP66

F - 2 pole cable

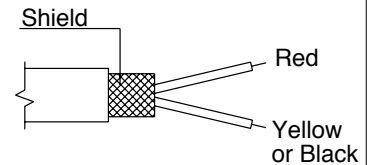

Shielded cable 2x0.25 - 2m.
Protection IP65

Z - 4 pole male connector M12 x 1

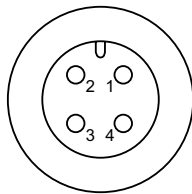

4 pole series 713 male connector
Protection IP67

E - 4 pole solenoid connector M - 4 pole microsolenoid connector

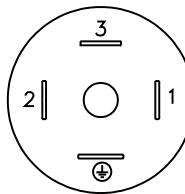

Solenoid DIN 43650A - ISO4400
Protection IP65
Microsolenoid DIN 43650C - ISO4400
Protection IP65

H - 4-pole connector

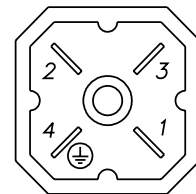

Male connector G4A1M
Protection IP65

ELECTRICAL CONNECTION - Connection diagrams

CURRENT AMPLIFIED OUTPUT - mod. E

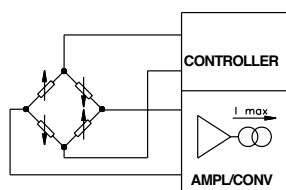

	cod. V	cod. P	cod. F	cod. E/M	cod. H	cod. Z
POWER SUPPLY +	A	3	Red	1	1	1
SIGNAL -	B	4	Yellow or Black	2	2	2
⊥	Case	Case	Shield	⊥	4	Case

LOAD DIAGRAM (Current output)

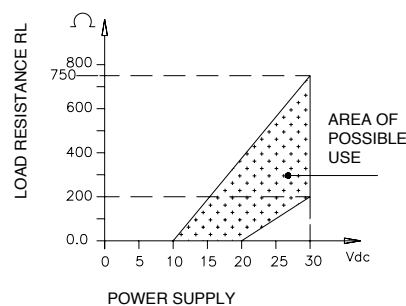

ACCESSORIES ON REQUEST

Connectors

Connection E

3 poles Connector + ground DIN43650A ISO4400
Prot. IP65

CON 006

Connection P

7 pole female cable connector
Prot. IP67

CON 321

Connection M

3 poles Connector + ground DIN43650C ISO4400
Prot. IP65

CON 008

Connection P

7 pole female cable connector
Prot. IP40

CON 320

Connection Z

4 pole female cable connector M12x1
Prot. IP67

CON 293

Connection P

7 pole female cable connector, 90°
Prot. IP40

CON 322

Connection Z

4 pole female cable connector, 90° M12x1
Prot. IP67

CON 050

Connection V

6 pole female cable connector
Prot. IP66

CON 300

ORDERING INFORMATION

Pressure transmitter

XSA

OUTPUT SIGNAL	
Standard	
4 .. 20 mA	E

PRESSURE CONNECTION	
Standard	
G 1/4 gas male	1
On request	
7/16-20UNF-2A male (SAE4 for AS4395-E)	2
G 1/2A (DIN 16288)	3
G 1/4 gas female	4

ELECTRICAL CONNECTIONS	
4-pole connector solenoid	E
Shielded cable	F
4 pole connector	H
4-pole connector microsolenoid	M
7 pole connector	P
6 pole connector	V
M12x1 - 4 pole connector	Z

CALIBRATION STANDARDS
Instruments manufactured by Gefran are calibrated against precision pressure calibration equipment which is traceable to International Standards.

Mechanical and/or electrical characteristics differing from standard may be arranged on request.

TEMPERATURE CLASS	
4	T4 (-40...+80°C)
5	T5 (-40...+70°C)
6	T6 (-40...+60°C)

RESPONSE TIME	
V	Fast (< 1msec)

ACCURACY	
T	± 0.15% FSO Typical

RANGE				
	bar		psi	
BV25	0..0,25		P05U	0..05
BV50	0..0,5		P15U	0..15
B01U	0..1		P03D	0..30
B02U	0..2		P05D	0..50
B2V5	0..2,5		P75U	0..75
B04U	0..4		P01C	0..100
B05U	0..5		P15D	0..150
B06U	0..6		P25D	0..250
B07U	0..7		P03C	0..300
B01D	0..10		P05C	0..500
B16U	0..16		P75D	0..750
B02D	0..20		P01M	0..1000
B25U	0..25			
B03D	0..30			
B04D	0..40			
B05D	0..50			
B06D	0..60			

Ex.: **XSA - E - 1 - E - B03D - T - V - 4**

Intrinsically safe pressure transmitter, with 4 to 20mA signal output, G 1/4 male pressure connection, DIN43650A solenoid electrical connector, 0...30 bar measurement range, ± 0.15% FSO accuracy, 1msec response time, T4 temperature class (-40...+80°C).

Sensors are manufactured in compliance with:

- EMC 2004/108/CE compatibility directive
- RoHS 2002/95/CE directive
- ATEX 94/9/CE

Electrical installation requirements and Conformity certificate are available on our web site: www.gefran.com

GEFRAN spa reserves the right to make any kind of design or functional modification at any moment without prior notice

GEFRAN spa

via Sebina, 74

25050 PROVAGLIO D'ISEO (BS) - ITALIA

tel. 0309888.1 - fax. 0309839063

Internet: <http://www.gefran.com>

GEFRAN

DTS_XSA_09-2010_ENG