



MAIN FEATURES

Electrical

- Digital output signal with DP404 CAN OPEN communication protocol
- Transmission frequency (Baud rate): 10 Kbaud to 1 Mbaud (default 500 Kbaud)
- Software selection of Baud rate and ID nodes
- Operation with 1 or 2 settable alarm limits
- "Autozero" for temperature compensation
- Zero and span drift compensation
- 80% FSO calibration signal

Mechanical

- Pressure ranges:
0-35 to 0-2000 bar / 0-500 to 0-30000 psi
- Accuracy: $< \pm 0.25\%$ FSO (H); $< \pm 0.5\%$ FSO (M)
- Hydraulic transmission system to guarantee temperature stability.(Hg)
- Quantity of Hg contained for model:
series MDE0 (30mm³); series MD1, MD2, MD3 (40mm³)
- Standard threading: 1/2-20 UNF, M18x1.5; other versions on request
- Autozero function by software
- Stainless steel 15-5 PH diaphragm with GTP coating
- For ranges below 100 bar – 1500 psi: stainless steel 17-7PH corrugated diaphragm with GTP coating

GTP (advanced protection) Coating with high resistance against corrosion, abrasion and high temperature

The MD series of Gefran, are pressure transmitters for using in High temperature environment.
The main characteristic of this series is the capability to read temperature of the media up to 400°C.
The constructive principle is based on the hydraulic transmission of the pressure.
The fluid-filled system assures the temperature stability.
The physical measure is transformed in a electrical measure by means the strain-gauge technology.

TECHNICAL SPECIFICATIONS

Rated precision, including effects of linearity, repeatability and hysteresis	H $< \pm 0.25\%$ FSO (100...2000 bar) M $< \pm 0.5\%$ FSO (35...2000 bar)
Sampling	16 bit (1)
Pressure ranges	0-500 to 0-30.000 psi 0-35 to 0-2000 bari
Maximum applicable pressure	2 x FSO
Measurement principle	Strain gauge
Power supply	12...40 Vdc
Typical input	20 mA (2)
Insulation resistance (at 50Vdc)	>1000 MOhm
Signal at rated pressure (FSO)	Depends on FSO
Signal at ambient pressure	0
Calibration of ambient pressure	Insertion of an offset
Signal protocol	DP404 CAN OPEN, with baud rate selectable from 10K to 1M baud (default 500 Kbaud)
Response time (10 at 90% FSO)	20 ms
Electronic response time (10 at 90% FSO)	2 ms
Calibration signal	80%FSO
Protection against overvoltage and reverse polarity of power supply	YES
Compensated temperature range of strain gauge housing	0...+85°C 32...+185°F
Maximum temperature range of strain Gauge Housing	-30...+105°C -22...+221°F
Thermal drift in Zero compensated range; Calibration Sensitivity	$< 0.02\%$ FSO/°C $< 0.01\%$ FSO/°F $< 0.01\%$ FSO/°F
Max. diaphragm temperature	400°C (750°F)
Influence due to variation of fluid temperature (zero)	15 Psi/100°F 0.02bar/°C
Standard material in contact with process medium	Diaphragm: • 15-5 PH with GTP coating • 17-7 PH corrugated diaphragm with GTP coating for ranges <100 bar (1500psi) Stem: • 17-4 PH
Thermocouple (model MD2)	STD: Type * J (isolated coupling)
Protection level	IP65
Electrical connections	M12 DIN EN 50044 5-pin connector
(1) resolution: 0.01bar from 35...500bar; 0.1bar from 700...2000bar; 0.1psi from 5000 ...350psi; 1psi from 7500...30000psi	
(2) Conditions: Power supply 24 Vdc	
FSO = Full Scale Output (Signal at rated pressure)	

MECHANICAL DIMENSIONS

MDO

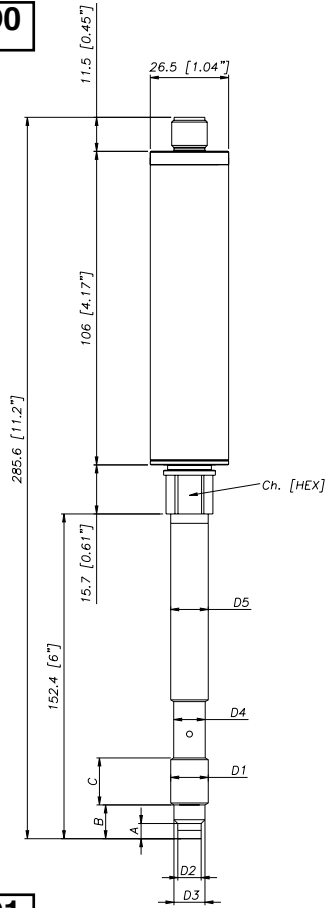

D1	1/2 - 20UNF
D2	$\phi 7.8 - 0.05$ [$\phi 0.31$ - 0.002]
D3	$\phi 10.5 - 0.025$ [$\phi 0.41$ - 0.001]
D4	$\phi 10.67$ [$\phi 0.42$]
D5	$\phi 12.7$ [$\phi 0.5$]
A	5.56 - 0.26 [0.22 - 0.01]
B	11.2 [0.44]
C	15.74 [0.62]
Ch	16
[Hex]	[5/8]

MD1

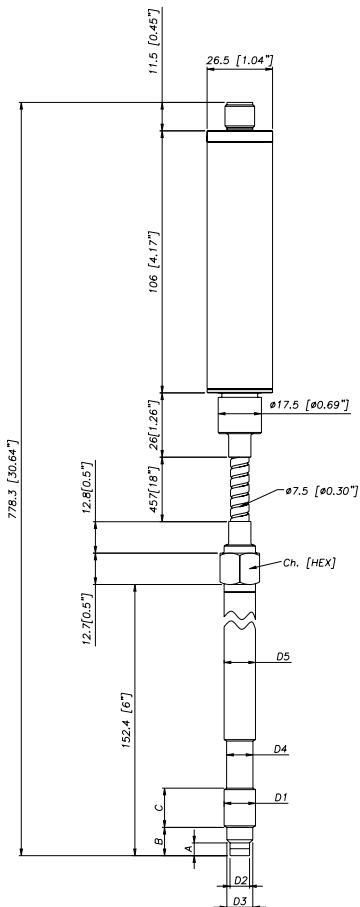

D1	M18x1,5
D2	$\phi 10 - 0.05$ [$\phi 0.394$ - 0.002]
D3	$\phi 16 - 0.08$ [$\phi 0.63$ - 0.003]
D4	$\phi 16 - 0.4$ [$\phi 0.63$ - 0.016]
D5	$\phi 18$ [$\phi 0.71$]
A	6 - 0.26 [0.24 - 0.01]
B	14.8 - 0.4 [0.58 - 0.016]
C	19 [0.75]
Ch	19
[Hex]	[3/4]

MD2

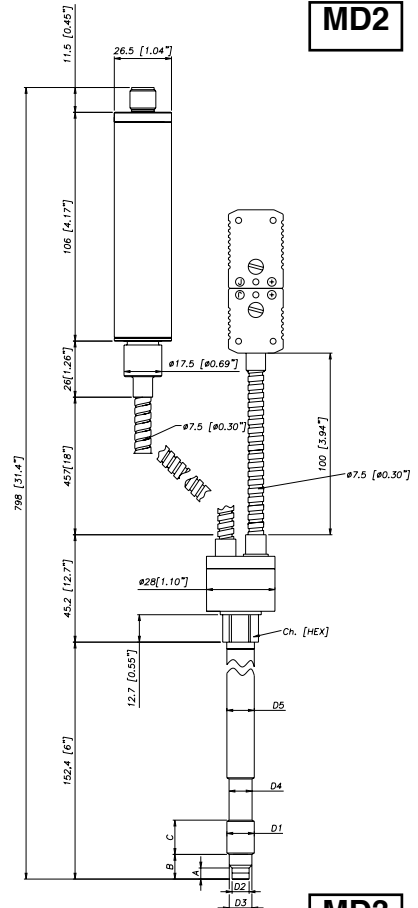

MD3

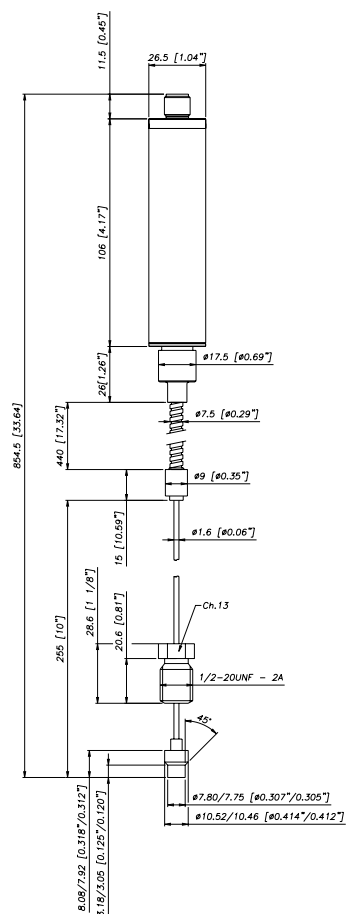

NOTE : dimensions refer to rigid stem length option “4” (153 mm – 6”)

WARNING : For installation use a maximum tightening torque of 56 Nm(500 in-lb)

ELECTRICAL CONNECTIONS

CAN BUS DP404 DIGITAL OUTPUT

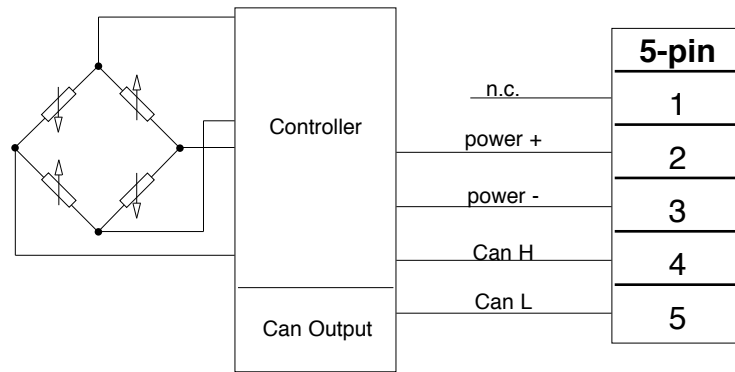

Shielding is connected to transducer body. It is advisable to ground it on the instrument side as well

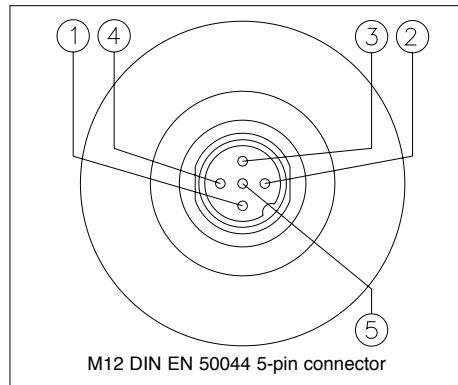

ACCESSORIES

Connectors

5 pin female connector (IP65 protection)

CON031

Extension cords

5-pin connector with cord length 1 meter (3.3 ft)

PCAV310

5-pin connector with cord length 2 meters (7 ft)

PCAV311

5-pin connector with cord length 5 meters (17 ft)

PCAV314

Other lengths

on request

Accessories

Fastening bracket

SF18

Protective plug for 1/2 - 20 UNF

SC12

Protective plug for M18x1.5

SC18

Punch kit for 1/2-20 UNF

KF12

Punch kit for M18x1.5

KF18

Cleaning kit for 1/2-20 UNF

CT12

Cleaning kit for M18x1.5

CT18

Cord color code

Conn.	Wire
1	n.c.
2	Red
3	Black
4	White
5	Blue

ORDER CODE

M - - - - - 000

OUTPUT SIGNAL	
CAN BUS	D

CONFIGURATION	
Rigid rod	0
Rigid + flexible rod	1
With thermocouple	2
Exposed capillary	3

CONNECTOR	
Standard	
5-pin M12	5

PRECISION CLASS	
$\pm 0.25\%$ (ranges ≥ 100 bar/1500 psi)	H
$\pm 0.5\%$	M

MEASUREMENT RANGE			
bar		psi	
35	B35U	500	P05C
50	B05D	750	P75D
70	B07D	1000	P01M
100	B01C	1500	P15C
200	B02C	3000	P03M
350	B35D	5000	P05M
500	B05C	7500	P75C
700	B07C	10000	P10M
1000	B01M	15000	P15M
1400	B14C	20000	P20M
2000	B02M	30000	P30M

000= Special executions of the standard version or custom versions may be ordered on request

LENGTH OF FLEXIBLE ROD (mm / inches)

Standard (MD0)	
0	none
Standard (MD1, MD2)	
D	457mm 18"
E	610mm 24"
F	760mm 30"
Standard (MD3)	
L	711mm 28"
On request	
A	76mm 3"
B	152mm 6"
C	300mm 12"
G	914mm 36"
H	1067mm 42"
I	1220mm 48"
J	1372mm 54"
K	1520mm 60"

LENGTH OF RIGID ROD (mm / inches)

Standard (MD0, MD1, MD2)	
4	153mm 6"
5	318mm 12.5"
Standard (MD3)	
0	none
On request	
1	38mm 1.5"
2	50mm 2"
3	76mm 3"
6	350mm 14"
7	400mm 16"
8	456mm 18"

THREADING

Standard	
1	1/2 - 20 UNF
4	M18 x 1.5
On request	
2	M10 x 1
3	M14 x 1.5

Example

MD0-5-M-B07C-1-4-0-000

Melt pressure transducer with Can output, 5-pin connector, 1/2 - 20 UNF threading, pressure range 700 bar, precision class 0.5%, 153 mm (6") rigid rod.

MD1-5-M-P03M-1-4-D-000

Melt pressure transducer with Can output, 5-pin connector, 1/2 - 20 UNF threading, pressure range 3000 bar, precision class 0.5%, 153 mm (6") rigid rod, 457 mm (18") flexible rod.

Sensors are manufactured in compliance with:

- EMC 2004/108/CE compatibility directive
- RoHS 2002/95/CE directive

Electrical installation requirements and Conformity certificate are available on our web site: www.gefran.com

GEFRAN spa reserves the right to make aesthetic or functional changes at any time and without notice.

GEFRAN spa

via Sebina, 74
25050 PROVAGLIO D'ISEO (BS) - ITALIA
tel. 0309888.1 - fax. 0309839063
Internet: <http://www.gefran.com>

GEFRAN

DTS_MD_09-2010_ENG