



The "IMPACT" series of Gefran, are pressure transmitters, without transmission fluid, for using in High temperature environment (350°C).

Medium pressure is transferred directly to the sensitive silicon element via a thick diaphragm.

Strain is transduced by a micro-worked silicon structure (MEMS).

The operating principle is piezoresistive.

"IMPACT" is Gefran's exclusive series of high-temperature pressure sensors that use the piezoresistive principle.

The main characteristic of "IMPACT" sensors is that they do not contain any transmission fluid.

The sensitive element, directly positioned behind the contact membrane, is realised in silicon through microprocessing techniques.

The micro structure includes the measurement membrane and piezoresistors.

The minimum deflection required by the sensitive element makes it possible to use very robust mechanics.

The process contact membrane can be up to 15 times thicker than the membrane used in traditional Melt sensors.

#### ADVANTAGES

- Total compatibility with the European RoHS Directive
- High strength
- Long life
- Working temperature: up to 350°C
- Excellent read stability over time
- Fast response time < 1ms

#### MAIN FEATURES

- Pressure ranges:  
0-100 to 0-1000 bar / 0-1500 to 0-15000 psi
- Accuracy: <  $\pm 0.25\%$  FSO (H); <  $\pm 0.5\%$  FSO (M)
- Standard threading 1/2-20UNF, M18x1.5; other versions on request
- Other types of diaphragms are available on request
- Autozero function on board / external option
- 15-5 PH stainless steel diaphragm GTP coated

#### AUTOZERO FUNCTION

All signal variations in the absence of pressure can be eliminated by using the Autozero function.

This function is activated by closing a magnetic contact located on the transmitter housing or by means of external autozero.

The procedure is permitted only with pressure at zero".

The Autozero function should be activated ONLY when the sensor is completely installed on the system.

#### TECHNICAL SPECIFICATIONS

Accuracy (1)	<b>H</b> $\leq \pm 0.25\%$ FSO <b>M</b> $\leq \pm 0.5\%$ FSO
Resolution	16 Bit
Measurement range	0..100 to 0..1000bar 0..1500 to 0..15000psi
Maximum overpressure (without degrading performances)	2 x FS 1.5 x FS above 700bar/10000psi
Measurement principle	Piezoresistive
Power supply	10...30Vdc
Maximum current absorption	32mA
Insulation resistance (at 50Vdc)	>1000 MOhm
Output signal Full Scale FSO	20mA
Zero balance (tolerance $\pm 0.25\%$ FSO)	4mA
Zero signals adjustment (tolerance $\pm 0.25\%$ FSO)	"Autozero" function
Maximum allowed load	See diagram
Response time (10...90% FSO)	8ms (option 1ms)
Output noise (RMS 10-400Hz)	< 0.025% FSO
Calibration signal	80% FSO
Output short circuit ingress and reverse polarity protection	YES
Compensated temperature range housing	0...+85°C
Operating temperature range housing	-30...+105°C
Storage temperature range housin	-40...+125°C
Maximum diaphragm temperature	350°C / 660°F
Zero signal variation due to process temperature variation in range (20-350°C)	< $\pm 1,2\%$ FSO
Full-scale signal variation due to process temperature variation in range (20-350°C)	< $\pm 1\%$ FSO
Std contact diaphragm with process Thermocouple	15-5 PH GTP STD: Type "J" (isolated junction) Type "K" (on request)
( Model IE2)	
Protection degree (with 6-pole female connector)	IP65
Electrical connection	Conn. 6-pin VPT07RA10-6PT (PT02A-10-6P) Conn. 8-pin PC02E-12-8P

FSO = Full scale output

(1) BFSL method (Best Fit Straight Line): includes combined effects of Non-Linearity, Hysteresis and Repeatability.



# MECHANICAL DIMENSIONS

**IE1M**

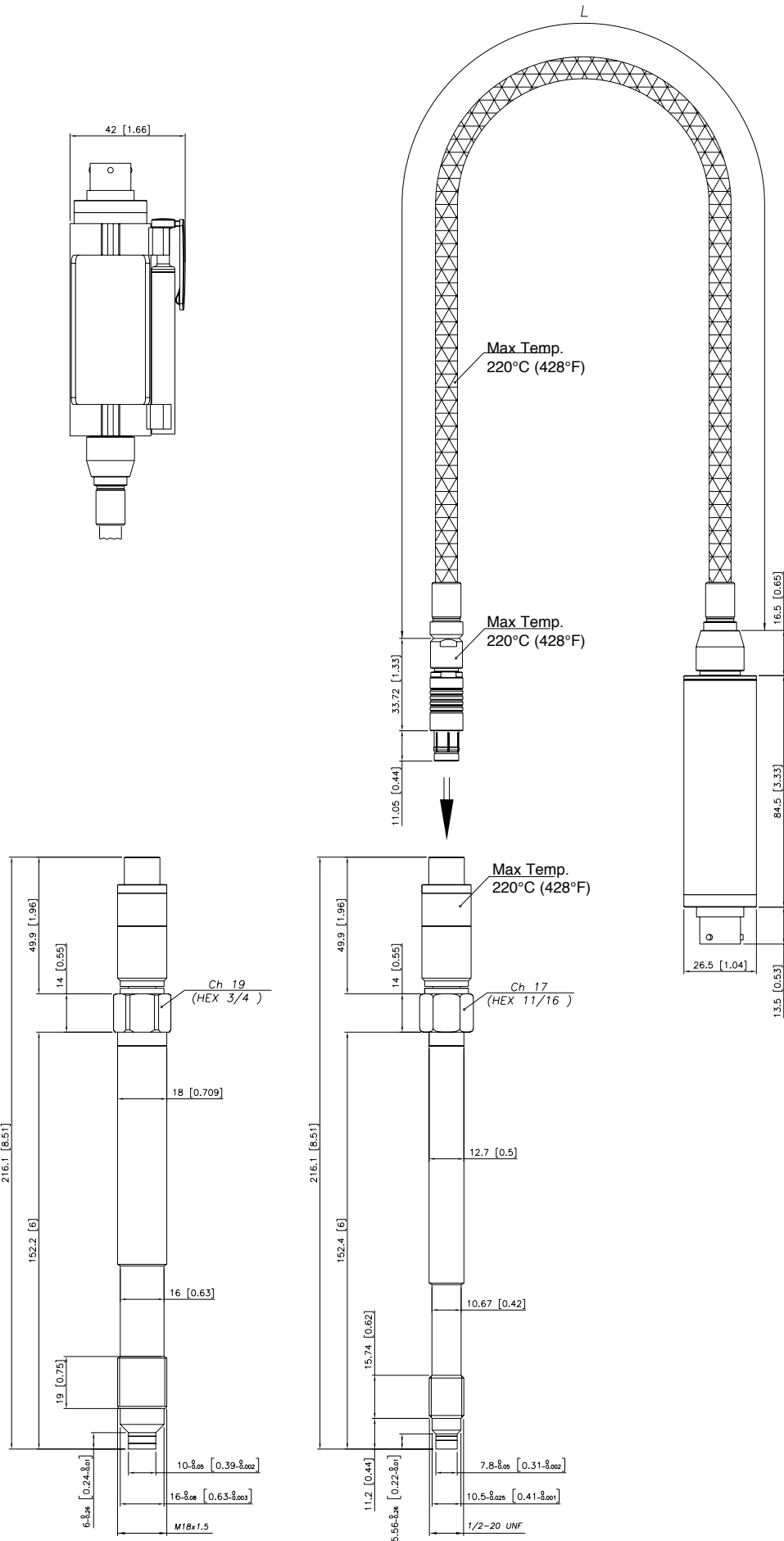

**NOTE :** dimensions refer to rigid stem length option "4" (153 mm – 6")

**WARNING :** For installation use a maximum tightening torque of 40 Nm (355 in-lb)

# MECHANICAL DIMENSIONS

**IE1S**

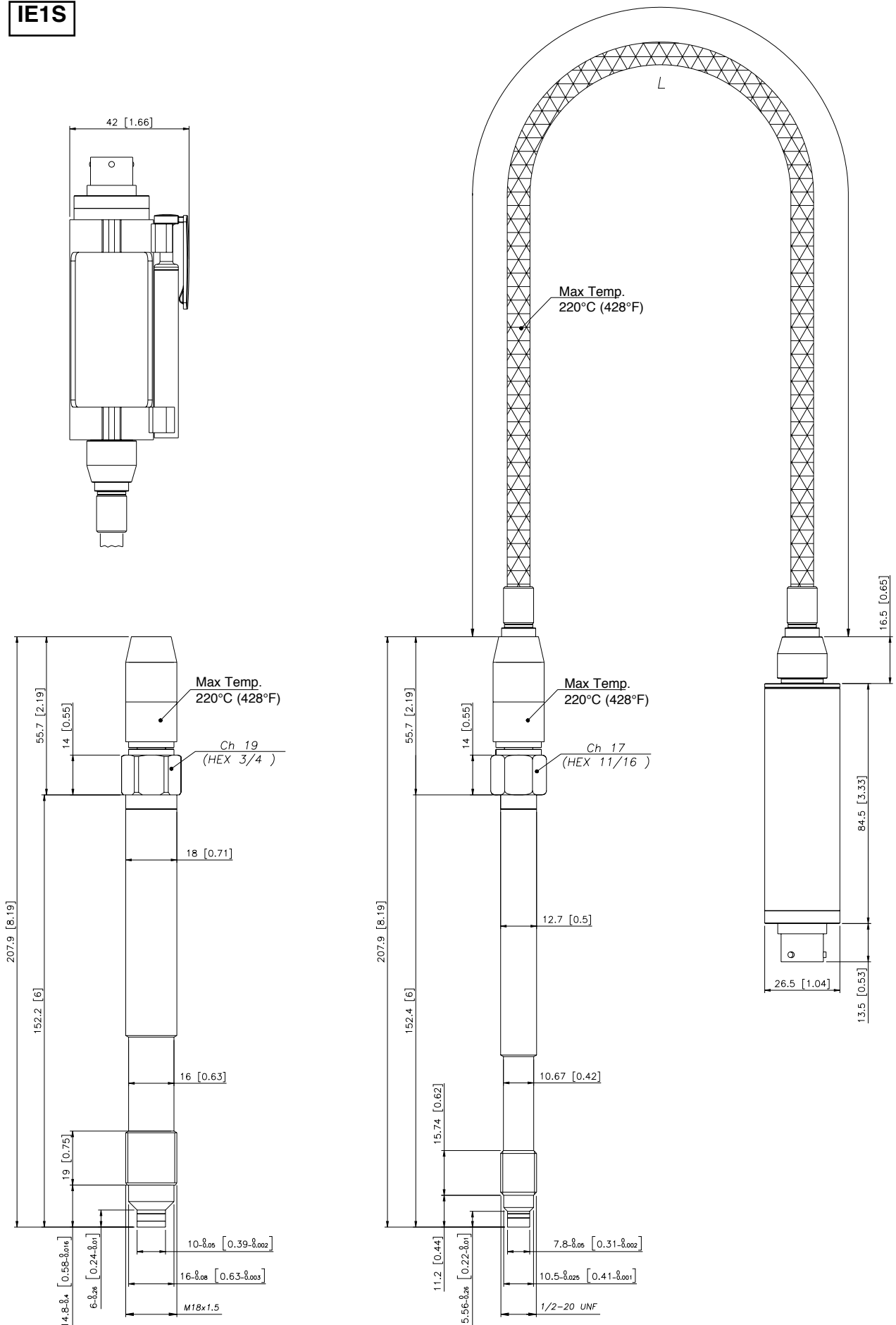

**NOTE :** dimensions refer to rigid stem length option “4” (153 mm – 6”)

**WARNING :** For installation use a maximum tightening torque of 40 Nm (355 in-lb)

# MECHANICAL DIMENSIONS

**IE2**

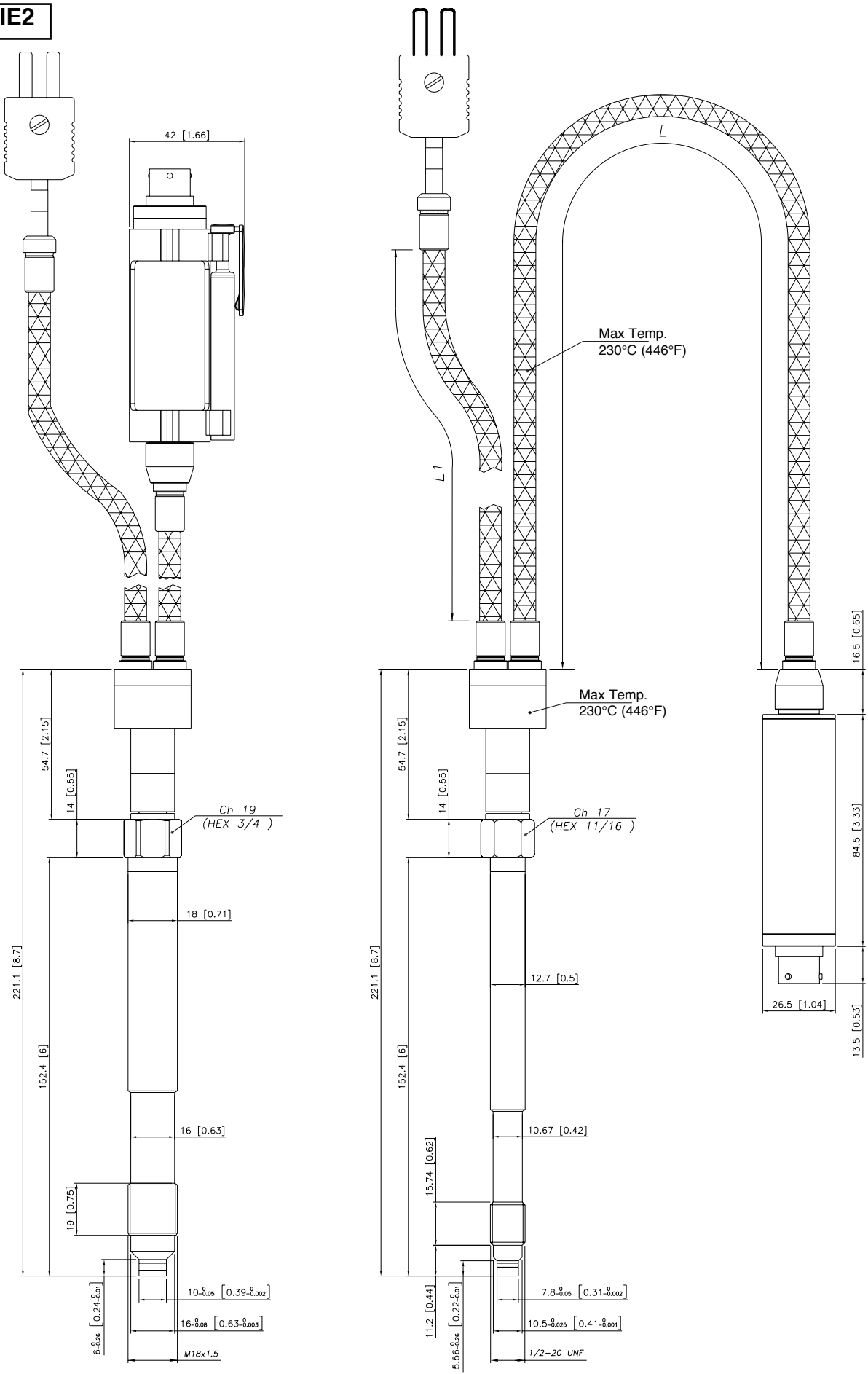

**NOTE :** dimensions refer to rigid stem length option "4" (153 mm – 6")

**WARNING :** For installation use a maximum tightening torque of 40 Nm (355 in-lb)

## ELECTRICAL CONNECTIONS

### CURRENT OUTPUT (4...20mA, 2-wires)

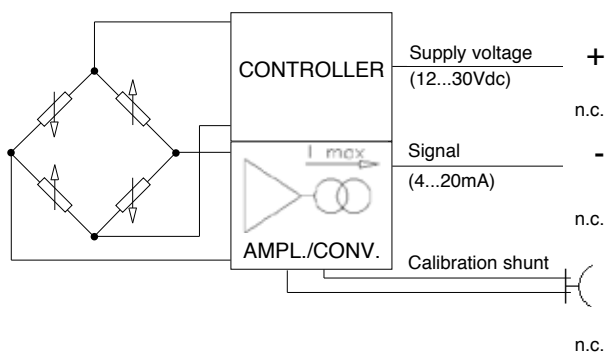

Shield drain wire is tied to connector via cable clamp

### MAGNETIC AUTOZERO

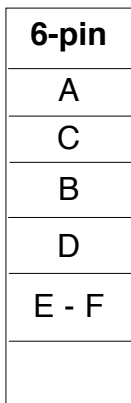

### EXTERNAL AUTOZERO

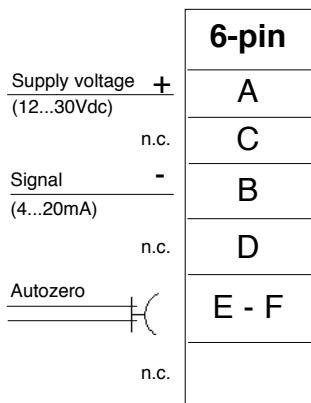

6 pin connector  
VPT07RA10-6PT2  
(PT02A-10-6P)

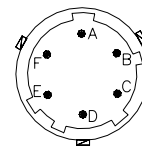

## LOAD DIAGRAM

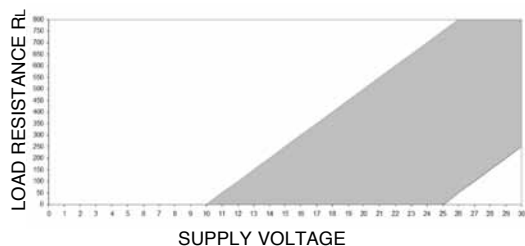

The diagram shows the optimum ratio between load and power supply for transmitters with 4...20mA output.

For correct function, use a combination of load resistance and voltage that falls within the shaded area.

## AUTOZERO FUNCTION

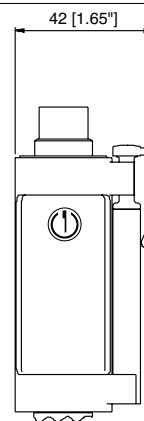

The Autozero function is activated through a magnetic contact (external magnet supplied with the sensor). See the manual for a complete Autozero function explanation.

## ACCESSORIES

### Connectors

6-pin female connector (IP65 protection degree)  
8-pin female connector

### Extension cables

6-pin connector with 8m (25ft) cable  
6-pin connector with 15m (50ft) cable  
6-pin connector with 25m (75ft) cable  
6-pin connector with 30m (100ft) cable

Other lengths

### Accessories

Mounting bracket  
Dummy plug for 1/2-20UNF  
Dummy plug for M18x1.5  
Drill kit for 1/2-20UNF  
Drill kit for M18x1.5  
Cleaning kit for 1/2-20UNF  
Cleaning kit for M18x1.5  
Fixing pen clip  
Autozero pen

CON300  
CON307

C08WLS  
C15WLS  
C25WLS  
C30WLS

on request

SF18  
SC12  
SC18  
KF12  
KF18  
CT12  
CT18  
PKIT309  
PKIT312

### Cable color code

Conn.	Wire
A	Red
B	Black
C	White
D	Green
E	Blue
F	Orange

